



QUAD TORC CONCEPT 2023





Contents

QTC 2023 EVENT TIMELINE.....	2
SECTION A – ADMINISTRATIVE REGULATIONS	3
A.1. About Quad Torc Concept	3
A.2. Competition Objective	3
A.3. Competition Procedure	3
A.4. Registration Process	4
A.5. Registration Fee	4
A.6. Fee Payment.....	4
A.7. Payment Confirmation	4
A.8. Team Member Registration	4
SECTION B – POWERTRAIN.....	5
B.1. Maximum Rated Power	5
B.2. Maximum System Voltage.....	5
B.3. Tractive System & Energy Storage.....	5
B.4. Tractive System Accumulator Container – General Requirements.....	5
B.5. Tractive System Accumulator Container - Mechanical Configuration	5
B.6. Accumulator Isolation Relay(s) (AIR).....	6
B.7. Accumulator Management System (AMS)	6
B.8. Tractive System Insulation, wiring and conduit.....	7
B.9. Tractive System Disconnect (TSD).....	7
B.10. Activating the Tractive System (Start Button/Drive Enable Switch)	8
B.11. Ready-To-Drive-Sound (RDS)	8
B.12. Power Shutdown Switch (PSS)	8
B.13. Accumulator Charger	8
B.14. Tractive Motor & Controller.....	9
B.15. Circuit Diagrams.....	9
SECTION C – EVALUATION PROCEDURE	10
C.1. Design Event	10
C.2. Cost Event	11
SECTION D – AWARDS	14



QTC 2023 EVENT TIMELINE

Activity	Date
Primary Registration	1 Dec – 31 Dec 2022
Registration Fee Payment	5 Jan 2023
Free Webinar on Quad Torc Concept 2023	22 Jan 2023
DSS Submission	24 Feb 2023
Free Mentorship Sessions	20 Feb – 15 Mar 2023
FMEA Submission	1 Mar 2023
Engineering Design Documents Submission	10 Mar 2023
Cost Report Documents Submission	15 Mar 2023
Team Member Information	25 Mar 2023
Online Design Presentation	10 Apr – 20 Apr 2023
Online Cost Presentation	20 Apr – 30 Apr 2023
Awards Ceremony	1 May 2023



SECTION A – ADMINISTRATIVE REGULATIONS

A.1. About Quad Torc Concept

Quad Torc Concept is the virtual design competition for the teams aiming to enter into the main competition and have less experience and exposure in the field vehicle designing and manufacturing. For this category the physical prototype of the vehicle is not required, however, teams can choose to present the physical components/systems/assemblies, if available. India's vision of only electric cars by the year 2030 motivates us to bring this new category to the series of design competitions by ISNEE Motorsports which challenges teams to design an electric Quad Bike.

The purpose of the Quad Torc Concept is to provide teams with an opportunity to conceptualize and design an electric Quad Bike which meets the Quad Torc Rules and Guidelines.

A.2. Competition Objective

The objectives of the challenge include the following:

- To provide a platform for students aiming to build an Electric Quad Bike for the Quad Torc
- To assist teams with mentors who will be able to guide them through the process of designing and manufacturing the Quad Bike
- Act as a platform for students interested in fabricating the competition vehicle without investing huge amount
- To improve the level of teams aiming to take part in Quad Torc

A.3. Competition Procedure

- The competition is organized by ISNEE Motorsports Private Limited, and shall be hosted online.
- The competition shall be based around electric Quad Bike.
- The physical prototype of the vehicle is not required, however, teams can choose to present the physical components/systems/assemblies, if available.
- The design and rule guidelines shall be followed from the most recent Quad Torc Rulebook published on [QT Website](#) and this Handbook.
- Every evaluation shall be recorded and every report submitted by the teams shall be considered a "Public Report" (Article 1.8 of 9th QT Rulebook) and can be reproduced and distributed by the competition organization, in both complete and edited versions, in any medium or format anywhere in the world.
- The events shall also involve its own Q&A session with the relevant judging groups in scheduled time slots.
- Scoring of the events in the competition is done as follows:

Category	Specifics	Points
DSS	Design Spec Sheet + Q&A	50
FMEA	FMEA Report + Q&A	50
ENGINEERING DESIGN	Design Report + Design Presentation + Supporting Documents + Q&A	300
COST REPORT	Cost Report + Supporting Documents + Q&A	100
TOTAL		500



A.4. Registration Process

- Primary registration of the team can be done on <https://isnee.in/registration/QT-Registration.aspx>
- For those who intend to make payment via their institution or a private firm, please ensure that you provide the correct details of the Institution Name, Mailing Address and GSTIN. If yes, please share this information with the organizers before being invoiced.

A.5. Registration Fee

- The registration fee (non-refundable and non-transferable) of the Quad Torc Concept is ₹ 16500 + 18% GST.
- For those who intend to make payment via their institution or a private firm, please ensure that you provide the correct details of the Institution Name, Mailing Address and GSTIN. If yes, please share this information with the organizers before being invoiced.

A.6. Fee Payment

- Once the primary registration is verified and approved, the team shall receive a confirmation email (from info@isnee.in) on the registered email id. In some cases, this email might be found in the spam box, we advise you to check the spam folder, and add info@isnee.in as a trusted contact if you don't find the mail in your inbox.
- This email contains the Team Account credentials including the Registration ID and Password, teams can login into the Team Account on EMS using this id and password.
- Teams shall receive a Proforma Invoice (PI) within 12 hours of the registration which will remain valid until the fee payment deadline mentioned in the document. Teams can use the following modes to make payment in line with the Proforma Invoice:
 - NEFT/IMPS
 - UPI/GPAY/PHONEPE
 - Payment Gateway (PayU Money) integrated with the Team Account on EMS

A.7. Payment Confirmation

- Once the payment is made, the reference can be sent to the WhatsApp helpline for confirmation.
- Upon the successful confirmation of the fee payment, the team shall receive a Tax Invoice on the registered email.

A.8. Team Member Registration

- The maximum number of members in a team is limited to 25; wherein 15 members can be registered without any extra charges while next 10 can only be added after paying ₹ 690 + 18% per member.
- The Team Member Information (TMI) must be completed in the Team Account on EMS.



SECTION B – POWERTRAIN

B.1. Maximum Rated Power

The maximum power drawn from the battery must not exceed 6kW. Teams are free to use multiple motors (AC/DC).

B.2. Maximum System Voltage

The maximum voltage in the tractive system must not exceed 72V.

B.3. Tractive System & Energy Storage

- **Tractive System** - The tractive system of the quad is defined as every part that is electrically connected to the motor(s) and tractive system accumulators.
- **Tractive System Accumulator** - The Tractive system accumulator is defined as all the battery cells or super-capacitors that store the electrical energy to be used by the tractive system.
- **Allowed Tractive System Accumulators –**
 - All types of accumulators except molten salt and thermal batteries are allowed. E.g.: Batteries, Super-capacitors, etc. Fuel cells are prohibited.
 - During the online presentation it is **mandatory** for the teams to show the **Technical data sheets** (AMS & Cells Used in case of a Lithium Ion Battery and similar components) of the Accumulator even if Team has outsourced it form a Vendor.

B.4. Tractive System Accumulator Container – General Requirements

- Cells, which store the tractive system energy will be built into accumulator segments and must be enclosed in (an) accumulator container(s).
- If spare accumulators are to be used then they all have to be of the same size, weight, and type as those that are replaced.
- Each accumulator container must be removable from the quad while still remaining rules compliant.

B.5. Tractive System Accumulator Container - Mechanical Configuration

- All accumulator containers must lie within the Primary Structure of the Frame.
- The accumulator container must be built of mechanically robust material.
- The content material must be fire-resistant.
- All accumulator containers must be protected from any sort of impact collisions by structure.
- All accumulator containers must be designed to withstand forces from deceleration.
- Accumulator containers must be constructed of sheet/plate steel or composites that include aramid or glass fiber.
- Accumulator containers must be attached to the major structure of the chassis
- Holes, both internal and external, in the container are only allowed for the wiring-harness, ventilation, cooling or fasteners.



- The container must be completely closed at all times when mounted on the quad and also when dismantled from the quad without the need to install extra protective covers. Openings for ventilation should be of a reasonable size, e.g., completely open seedpods containing accumulators are not allowed.
- A sticker with an area of at least 750 sq mm and a red or black lightning bolt on a yellow background or red lightning bolt on white background must be applied on every accumulator container. The stickers must also contain the text "High Voltage" or something similar.



B.6. Accumulator Isolation Relay(s) (AIR)

- In every accumulator container at least two isolation relays must be installed to isolate High Voltage battery in case of any emergency. AIR must be present at each HV+ and HV- terminals.
- The accumulator isolation relays must open both poles of the accumulator when not activated.
- The isolation relays must be of a "normally open" type.
- AIR coils should be **controlled using low voltage circuit only**. Contactors having coil with High Voltage rating not to be used. i.e., High voltage controls of AIR Coil are strictly prohibited.
- **AIR operation** should be clearly **demonstrated** from outside. If it is inside the battery pack, then controls of AIR need to be shown during technical inspection.
- The fuse protecting the accumulator tractive system circuit must have a rating lower than the maximum current rating of the isolation relays.
- The accumulator isolation relays must not contain mercury.
- It is mandatory for the team to show the **Technical data sheet** of the AIR.

B.7. Accumulator Management System (AMS)

- Each accumulator must be monitored by an accumulator management system whenever the tractive system is active or the accumulator is connected to a charger.
- The AMS must continuously measure the cell voltage of every cell, in order to keep the cells inside the allowed minimum and maximum cell voltage levels stated in the cell datasheet. If single cells are directly connected in parallel, only one voltage measurement is needed.
- The AMS must shutdown the tractive system by opening the AIRs, if critical voltage or temperature values according to the cell manufacturer's datasheet and taking



into account the accuracy of the measurement system are detected. If the AMS does perform a shutdown, then a red LED marked AMS must light up in the cockpit to confirm this.

- It is mandatory for the team to show the **Technical data sheets** of the AMS, even in case of you outsourced it form a Vendor.

B.8. Tractive System Insulation, wiring and conduit

- All parts, especially live wires, contacts, etc. of the tractive system must be isolated by non- conductive material or covers to be protected from being touched.
- Non-conductive covers must prevent inadvertent human contact with any tractive system voltage. This must include crewmembers working on or inside the quad. Covers must be secure and adequately rigid. Body panels that must be removed to access other components, etc. are not a substitute for enclosing tractive system connections.
- Tractive system components and containers must be protected from moisture in the form of rain or puddles.
- All tractive system wiring must be done to professional standards with appropriately sized conductors and terminals and with adequate strain relief and protection from loosening due to vibration etc.
- All tractive system (High Voltage) wiring that runs outside of electrical enclosures must either be enclosed in separate orange non-conductive conduits or use an orange-shielded cable.
- Tractive system wiring must be shielded against damage by rotating and / or moving parts.
- If external, un-insulated heat sinks are used, they must be properly grounded to the GLV System ground.
- Wiring that is not part of the tractive system must not use orange wiring or conduit. I.e., LV circuits should use wiring or conduits of any colors other than orange.

B.9. Tractive System Disconnect (TSD)

- It must be possible to disconnect at least one pole of the tractive system accumulator by quickly removing an unobstructed and directly accessible element, fuse or connector, in case of (a) stuck accumulator isolation relay(s) for example. It must be possible to disconnect the tractive system without removing any bodywork. The TSD must be above 300mm from the ground and easily visible when standing behind the quad. Remote actuation of the HVD through a long handle, rope or wire is not acceptable.
- An untrained person must be able to remove TSD within 10 seconds in ready-to-race conditions. This will be tested during the Electrical Tech Inspection. Being able to quickly disconnect the accumulator(s) from the rest of the tractive system by its connector(s) will satisfy this rule.
- The TS Disconnect must be clearly marked with "TSD".
- No tools must be needed to open the TSD. Therefore, an interlock must activate the shutdown circuit and open the AIRs when the TSD is removed.
- It is mandatory for the team to show the **Technical data sheet** of the TSD.



B.10. Activating the Tractive System (Start Button/Drive Enable Switch)

- The driver must be able to (re-)activate or reset the tractive system from within the cockpit without the assistance of any other person.
- Closing only the shutdown circuit must not set the quad to ready-to-drive mode. Additional actions are required by the driver to set the quad to ready-to-drive-mode e.g., pressing a dedicated start button after the tractive system has been activated
- This Start Button/Drive Enable switch should be near/on the steering wheel and it should be easily accessible to the driver.

B.11. Ready-To-Drive-Sound (RDS)

- The quad must make a characteristic sound, continuously for at least 1 second and a maximum of 3 seconds when it is ready to drive.
- The used sound must be easily recognizable. No animal voices, song parts or sounds that could be interpreted, as offensive will be accepted.
- The quad must not make any other sounds similar to the ready to drive sound.

B.12. Power Shutdown Switch (PSS)

- The PSS is part of the shutdown circuit and directly carries the current driving the accumulator isolation relays (AIRs).
- **PSS** can also be referred as **Kill Switch/Emergency Button** in an EV.
- There must be two PSS/Kill Switches on the quad. The first PSS must be rigidly mounted **on the steering handle** where the driver can easily operate it. The second PSS should be placed on the **rear left side of the vehicle** at an adequate height such that in an emergency situation the bystander can operate it easily. This PSS must be easily visible to someone standing near the quad.
- These PSS must cut off all HV & other electrical connections when engaged.
- The operation of the PSS must be push-to-kill
- Refer to the image below for the type of PSS/kill switches to be used.
- Kill switches, which need continuous pressure to be applied for the operation, are not allowed.



B.13. Accumulator Charger

- Teams are free to use any charger compatible with the Accumulator ratings.
- It is mandatory for the team to show the **Technical data sheet** of the Charger.



B.14. Tractive Motor & Controller

- Motor & Controller are essential part of any EV. You are free to use any Motor/Controller with Voltage/Power ratings less than or equal to that defined in this handbook.
- It is mandatory for the team to show the **Technical data sheets** of the Motor & Controller, even in case of you outsourced it form a Vendor.

B.15. Circuit Diagrams

There are mainly two types of circuit involved in the vehicle:

- LV Circuit (Low Voltage, Shutdown Circuit)
- HV Circuit (High Voltage, Tractive System)

It is **mandatory** to produce HV & LV circuit diagram specific to your connection in the vehicle during presentation.

This diagram below is the overall block Diagram of the **Low Voltage Shutdown Circuit**.

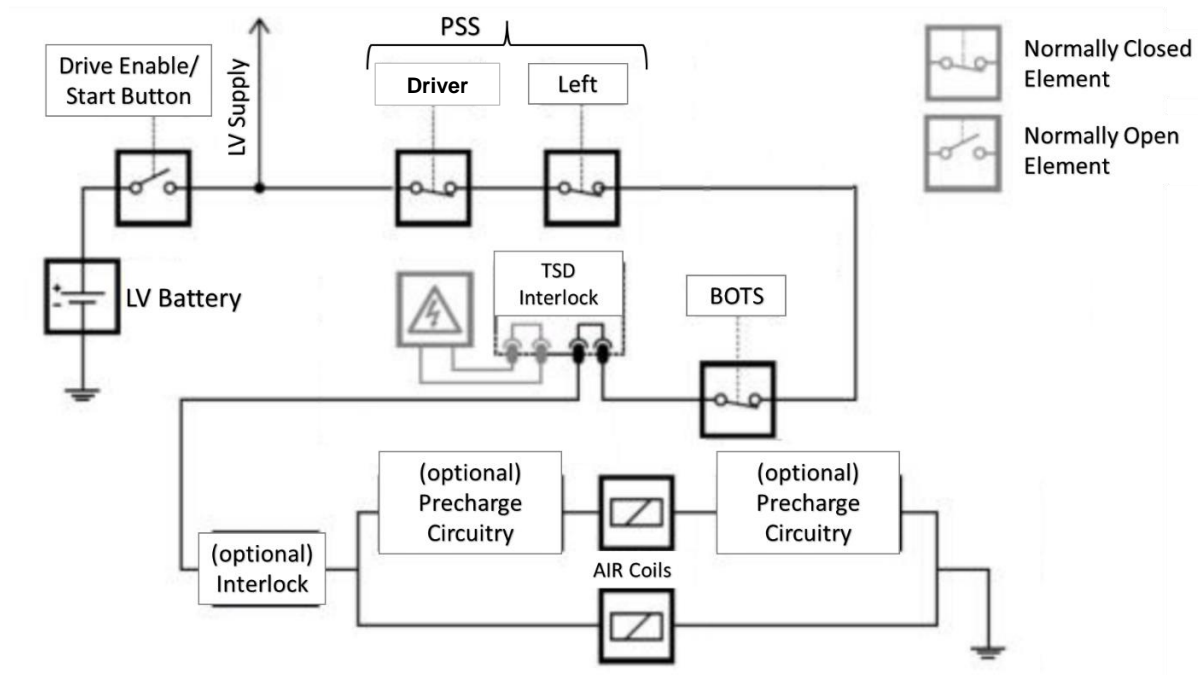

- The shutdown circuit directly carries the current driving AIRs. If the shutdown circuit is opened, the Tractive System must be shut down by opening all AIRs. It is mandatory for any EV Quad to adhere to the above Shut down circuit, however team is free to change the PSS/BOTS/TSD connection sequence.



- For additional safety you are free to add additional interlocks in the shutdown circuit apart from what were given in the rulebook. These additional safety circuits can be considered as innovation as well.

SECTION C – EVALUATION PROCEDURE

C.1. Design Event

The Design Event consists of the evaluation of DSS, FMEA, and Engineering Design. Templates of DSS, and FMEA can be found in Team Account on EMS under the “Resources” tab. The evaluation starts at the time of submission and completes in the online presentation. Teams must submit the following reports in order to be evaluated for the Design Event:

- **DSS – Design Spec Sheet** [template available]
- **FMEA – Failure Modes & Effects Analysis** [template available]
- **Engineering Design Report** - The Design Report (DR) must not exceed 9 pages including the cover page. Not more than 4 pages of text, 3 pages of drawings and one optional page containing the content to be defined by the team.
- **Design Support Document** – If any

C.2.1. Evaluation Procedure- The evaluation is to be completed in two stages; i.e., report submission and online presentation. Reports evaluation is done for 20% of the points and online evaluation is done for the rest of the 80% of points.

- Each team gets 50 minutes for the presentation that includes 5 minutes for joining and system setup, 30 minutes for the presentation, and 15 minutes for Q&A.
- Maximum 6 members can involve in presentation and Q&A, however, rest of the team members can join for the purpose of learning from the evaluation and feedback.
- The sequence of presentation must address DSS first, then Engineering Design, and FMEA at the end.
- There is no limit on the number of slides in the presentation but teams must keep the content that can be presented within 30 minutes efficiently and effectively.
- The presentation will not be interrupted by Q&A, the Q&A starts at the 36th minute of the presentation. Presentations will be stopped right at the 35th minute; contents left (if any) will not be considered for presentation after this time.
- Every evaluation shall be recorded and every report submitted by the teams shall be considered a “Public Report” (Article I.8 of 9th QT Rulebook) and can be reproduced and distributed by the competition organization, in both complete and edited versions, in any medium or format anywhere in the world.
- Details of scoring fields can be viewed in the team account under the “Resources” tab at EMS.



C.2. Cost Event

The cost event is evaluated based on the submission of the “Cost Tables” and an online presentation. Template of “Cost Tables” can be found in Team Account on EMS under the “Resources” tab. The evaluation starts at the time of submission and completes in the online presentation. The main objectives of Cost Event are to teach the participants that cost and budget are significant factors that must be considered in any engineering practice.

- For teams to make trade off decisions between content and cost based on the performance advantage of each part and assembly.
- To gain experience with creating and maintaining a Bill of Material (BOM).
- For the participants to learn and understand the principles of Design for Manufacture and Assembly, lean manufacturing and Minimum Constraint Design.
- To provide a logical, simple and time efficient rule set enabling students to achieve the event's objectives.
- To improve fairness by providing consistent pricing guidelines independent of team geographical location by using standardized Cost Tables.
- To require the minimal burden of supporting documentation such as receipts or catalogue pages. However, in order to convey design information to cost judges engineering documentation (drawings, process descriptions, etc.) are required.

Teams must submit the following reports in order to be evaluated for the Design Event:

- Cost Tables [template available]
- Cost Supporting Document – If any

General requirements of Cost Tables are but not limited to:

- Use the standardized Cost Tables available in your account.
- List and cost every part on the prototype vehicle. This includes any equipment fitted on the vehicle at any time during the competition. The cost of any on-board fire suppression system, tires, video or radio system, and transponder does not need to be included in the Cost Report.
- Be based on the estimated costs of materials, fabrication, purchased parts, and assembly of the car. The costs must be calculated as defined in these rules.
- Be based on the actual manufacturing technique used on the prototype.
- Include tooling (e.g. welding jigs, moulds, patterns and dies) for processes requiring it.
- Exclude R & D and capital expenditures (e.g. plant, machinery, hand tools and power tools).
- There is no maximum or minimum cost. Receipts are not required for any items.

The Cost Tables have been designed to:

- Be verifiable at the event. Differentiating between different types of materials (for example different alloys of steel) is not possible so no differentiation is made in the table cost.
- Minimize influence on safety equipment content. For example, driver harnesses



are cost independent of the style chosen.

- Higher costs of some goods must reflect actually higher value of those goods. However, the costs must still allow for team innovation and vehicle content, with some reduction in cost score.

C.2.1. Submission Procedure- All the reports must be submitted as per the event timeline in the following manner:

- Teams must create a folder named as “**QTC2023-Team_Name**” on their google drive.
- Every submission must be renamed properly in accordance with the report names and the report name should be followed by the team name [e.g., FMEA-Team Garuda].
- A suitable report must be uploaded to the google drive folder on or before the deadline.
- Once the report is successfully uploaded on the drive, the team must intimate the organizers by sending an email to quadforc@isnee.in
- The link to the google drive folder must be included in the intimation email with sharing permission open to all of the mail ids mentioned below:
 - quadforc@isnee.in
 - info@isnee.in
 - info.isnee@gmail.com
- The subject of the intimation email must not be other than “**QTC2023_Report_Name-Team Name**”
- Teams can request for re-submission if in case wrong/improper reports are submitted. In such a case, the request for rectification is to be sent to quadforc@isnee.in within 3 business days after which no revisions shall be accepted. New reports will be accepted without any penalties if submitted within the stipulated time. Penalties are applicable as per the rulebook in case of late submission without prior permission.

C.2.2. Evaluation Procedure- The evaluation is to be completed in two stages; i.e., report submission and online presentation. Reports evaluation is done for 20% of the points and online evaluation is done for the rest of the 80% of points.

- Each team gets 40 minutes for the presentation that includes 5 minutes for joining and system setup, 20 minutes for the presentation, and 15 minutes for Q&A.
- Maximum 6 members can involve in presentation and Q&A, however, rest of the team members can join for the purpose of learning from the evaluation and feedback.
- There is no limit on the number of slides in the presentation but teams must keep the content that can be presented within 20 minutes efficiently and effectively.



- The presentation will not be interrupted by Q&A, the Q&A starts at the 26th minute of the presentation. Presentations will be stopped right at the 25th minute; contents left (if any) will not be considered for presentation after this time.
- Every evaluation shall be recorded and every report submitted by the teams shall be considered a “Public Report” (Article 1.8 of 9th QT Rulebook) and can be reproduced and distributed by the competition organization, in both complete and edited versions, in any medium or format anywhere in the world.
- Details of scoring fields can be viewed in the team account under the “Resources” tab at EMS.



SECTION D – AWARDS

The following awards (but not limited to) are presented by the competition:

1. Design Event
 - a. 1st Place
 - b. 2nd Place
 - c. 3rd Place
 - d. Best FMEA
 - e. Best Powertrain Package
 - f. Best Design
2. Cost Award
 - a. 1st Place
 - b. 2nd Place
 - c. 3rd Place
3. Overall Event
 - a. 1st Place
 - b. 2nd Place
 - c. 3rd Place

The Overall Top 3 teams will also receive a subsidy towards the registration fees at either of 9th or 10th Quad Torc (team can choose any one of these) main event in the following manner:

- 1st Place: ₹ 15,000
- 2nd Place: ₹ 10,000
- 3rd Place: ₹ 5,000